

SPEC HEAD AGREEMENT, CASE THEORY
AND THE SYNTAX OF PARTICIPLES:
ABSOLUTE PARTICIPIAL CLAUSES IN OLD ITALIAN.¹

Verner EGERLAND

The scope of this article is to investigate some issues concerning participial syntax through the analysis of absolute participial constructions in Old Italian. By 'Old Italian', I intend Florentine texts of the 14th century. We will build on, and amplify Belletti's (1990) approach to absolute participial constructions in contemporary Italian. It will be clear that absolute participial clauses from the ancient period observe patterns quite different from the modern grammar, and that they do so in a perfectly systematic and regular fashion. Our task will then be to define the difference between the two grammars (between 14th century language and modern language)². The parameters underlying the change, I will argue, are simple in nature, all relevant data will follow on two assumptions:

1. In Old Italian absolute clauses, but not in the Modern Grammar, an expletive object *pro* is licensed.

¹ This research was carried out during a stay at the Department of Linguistics, Florence. For criticism and fruitful discussion, I am grateful to Maria Rita Manzini, and the participants at the Florence seminar on generative grammar, above all Gloria Cocchi and Giuseppina Turano. I am also indebted to Anna Cardinaletti, Guglielmo Cinque, Kjell-Åke Gunnarsson, and Christer Platzack. Remaining errors are of course my own. The research was funded by Vetenskapsstiftelsen, Lund.

² The task is not trivial, as 14th century constructions, that in Belletti's model are not predicted, are sometimes marginally acceptable also for the modern speaker for whom they tend to belong to a higher or 'literary' register. I take these variations to be a matter of variety or style, avoiding however, the issue of how such notions are to be understood more precisely; see Sanworn (1989) and Kroch (1994) for discussion. As for the traditional discussion on Old Italian absolute constructions, the reader is referred to Ageo (1964), Rohlfs (1969), and Herczeg (1972). See also references cited there.

2. There is a Tense head in Old Italian participial absolutes, absent in Modern Italian (or, alternatively, present but 'inert').

Moreover, it may be possible to assume the first, object *pro*, to follow from the second, the presence or absence of T.

I will follow Kayne's hypothesis on Spec-head agreement and the *pro* theory as formulated in e.g. Rizzi (1982), (1986). I assume in essence the Minimalist Program (henceforth MPLT) as outlined by Chomsky (1992) and developed by e.g. Branigan (1992), Bobaljik & Jonas (1993), and Watanabe (1993); the analysis will diverge, however, from the most recent version of minimalism, Chomsky (1995). Since Belletti's (1990) account is not straightforwardly compatible with the MPLT, we must attempt a reformulation in minimalist terms.

Section 1 below is dedicated to a preliminary discussion of the *pro* theory in the MPLT framework. Building on this discussion, we will adapt Belletti's (1990) approach to the Minimalist Program in section 2. Under 3, we will proceed with the analysis of absolute participial clauses considering Old Italian evidence: Their internal structure 3.1. (with a short digression in 3.1.1.), Verb-raising 3.2., and DP-movement 3.3.. A brief comparison with gerundival constructions will be made in 3.4.. Under 4, we will consider some evidence for argumental *pro* in participials, reaching the conclusion that only subject *pro* can be argumental. Finally, we will pay attention to the *pro* theory of Rizzi (1986) and make our concluding remarks in section 5.

My aim is first and foremost to compare 14th century Italian data with contemporary use. In order to arrive at a more complete picture, these grammars should in turn be confronted with data from other, intermediate stages of Italian (the 16th century grammar shows patterns quite different from the two former) and from other Romance languages. Such considerations are however beyond the intentions of this work.

1. Spec Head Agreement and Rightward Agreement in the MPLT

At least since Chomsky (1986b), it is commonly assumed that agreement between a DP subject and the finite verb is the syntactic reflex of the local relation between a functional head (here: AgrS) and its Specifier. In Kayne (1989), the conclusion is generalized to participial agreement, through the introduction of an Agr node corresponding to the object, assumed also by Chomsky (1992) as AgrO.

Under such assumptions, the theory must offer some additional device to explain phenomena generally defined 'rightward agreement', as in cleft sentences or inversion structures:

- (1) Sono io che ...
'it is[+Agr] I that ...'

- (2) Hanno telefonato i tuoi amici.
'have[+Agr] telephoned your friends'
- (3) Sono arrivati alcuni dei miei amici.
'have[+Agr] arrived some of my friends'

In Chomsky (1981), Rizzi (1982) and Burzio (1986), the solution was linked to the theory of Null Subjects³. This was worked out so as to derive the phenomena of 'rightward agreement' and 'free subject inversion' from the property of pro-drop. It was thus crucially assumed that the 'inversion' of the subject in (2)-(3)⁴ is possible because Italian can license a null copy of the subject that occupies the Spec I position in which Nominative is assigned. The fact that the verb shows agreement with the subject to its right is explained on the same assumption; the V under Infl agrees with a null element in Spec I that copies the overt noun to the right.

Through the development of these ideas put forward by Chomsky (1992) the conclusion is strengthened. When reformulated in terms of the MPLT, the pro theory will in essence be forced on theoretical grounds: If a DP *can* raise to subject position, Spec AgrS, in overt syntax, it is because it *has* to. There must be a feature present on the DP itself that requires overt checking. Otherwise its raising would be blocked by both Procrastinate and Greed. If, then, the DP can also appear somewhere else, generally in final position, we must assume that the relevant feature is checked anyway and checking can only take place in a Spec head relation (with AgrS, in case DP is a subject). If Procrastinate, Greed or feature checking in the Spec head configuration, all of which crucial to MPLT, are to be upheld, the assumption of a null element in Spec AgrS that copies the overt DP will be forced (distinguishing languages that allow for null subjects, rightward agreement and free inversion from those that do not). Furthermore, as head government is eliminated

³ For discussion on pro, Case chains and inversion phenomena, the reader is referred to e.g. Chomsky (1986a), Brandi & Cordin (1989), and Shlonsky (1990); cf. Rizzi (1986) for inversion phenomena in adjectival small clauses (to which we return in the last section); for discussion in a recent minimalist framework, Cardinaletti (1995) and Chomsky (1995; sec. 4 and 5). See also e.g. Belletti (1988), Lasnik (1992) and Moro (1993) for alternative views.

⁴ The question whether the DP subject is in its basic position in (3), and right adjoined to VP in (2), or occupies some other position is not crucial. There must under all circumstances be a null element in the Spec I. Even if Nominative can be assigned under government to the subject in the adjoined position in (2), and even if the subject of (3) carries some Case different from Nominative (e.g. Belletti (1988); Lasnik (1992)), the Extended Projection Principle requires the presence of an expletive in Spec I. For some discussion on the Extended Projection Principle in MPLT, I refer also to Platzack (1994).

from the theory, direct Case assignment from Infl to a right adjoined subject, for instance in (2) or (3), is no longer possible.

I follow this program as I feel the predicted correlation between 'inversion' and rightward agreement is fundamentally correct. Old Italian contributes with interesting evidence. It is true that participles in the relevant period agreed with objects to their right. It is equally true, however, that when rightward agreement on participles was regular, the direct object could also appear in a position to the left of the participle V. That is to say, in those texts where structures such as (4) are attested:

- Aux part. O
- (4) a. (...) non veggiono, per ciò che **hanno chiusi li occhi** (...)
 'they cannot see because they have closed_[+Agr] there eyes'
 (Conv; I:IV)
- Aux part. O
- b. (...) come che tu **abbi perduti i tuoi denari** (...)
 'even if you have lost_[+Agr] your money'
 (Dec; II:5)

structures of the type (5), where the object holds a position to the left of the participle are also frequent:

- Aux O
- (5) a. Poscia che Dio **ebbe Adamo ed Eva**, per lo peccato ch'aveano fatto,
 'After God had Adam and Eve, for the sin they had committed,
 part.
tratti di paradiso...
 taken_[+Agr] from Paradise'
 (Vizi; VI)
- Aux O part
- b. si come afferma chi **ha li occhi chiusi** (...)
 'as he says who has the eyes closed_[+Agr]'
 (Conv; II:IV)
- Aux O part.
- c. (...) co' denari **avresti la persona perduta**.
 'with your money you would have your life lost_[+Agr]'
 (Dec; II:5)

Aux O part.

d. Lo sommo e potente Dio, (...), **ha lla natura umana creata...**

‘The highest and mighty God has the human nature created_[+Agr]’

(Nov.re; Intro.)

The position between auxiliary and participle is thus a Case position in Kayne’s terminology. I assume that the DP object in (5) is in the specifier of AgrO, being overtly Case checked against the participle in AgrO (cf. Egerland 1994, for some further discussion).

The above assumptions on overt Case checking and expletive *pro* leaves us with little choice concerning the cases of rightward agreement, (4): the Old Italian AgrO can license an expletive *pro*, which occupies the Spec AgrO in overt syntax, allowing the DP to remain in situ. (6) thus corresponds to the constructions in (5) and (7) to those in (4):

(6) [_{AgrOP} DP(O)*i* [_{AgrO} AgrO [_{VP} V *ti*]]]

(7) [_{AgrOP} *pro**i* [_{AgrO} AgrO [_{VP} V DP(O)*i*]]]

Kayne (1989; p. 96) indeed assumes that a null pronominal is involved in structures such as (4). What he hypothesizes, however, is a (resumptive) clitictrace dependency, with the object DP dislocated to the right. What we suggest here is quite simply an expletive *pro* at the top of an A-chain, taking object shift to be A-movement, cf. Déprez (1989), Mahajan (1990), and Branigan (1992). The ‘inversion’ property of objects in Old Italian, illustrated in (4)/(5), is the option for a DP object to be overtly shifted, as in (5), or remain in situ, as in (4). The core case of the null subject theory thus carries over to participle-object constructions.

Generally speaking, the possible approaches to rightward agreement are the following:

1. We admit for alternatives to the Spec head agreement approach, saying that agreement can be realized in the relation between a head and its complement. This is the suggestion of Belletti (1990). I will from now on call this hypothesis HCA (Head Complement Agreement).
2. We insist on the Spec head approach to agreement (henceforth: SHA), and reject alternative 1. If SHA is to be followed consequently, there are two ways to address the problem posed by rightward agreement, both of which originating in Rizzi (1982):
 - 2a. As above, we can posit a null pronominal that takes the place of the DP in overt syntax.

2b. We can assume some version of the V-to-Comp strategy, i.e. that the DP moves overtly to the Spec position corresponding to an Agr head, after which the Verb is raised to this Agr head, *and beyond it*, in order to appear higher up in the structure than the DP (Kayne (1989); Belletti (1990))

Confronting the Old Italian data in (4)-(5) with those of modern Romance varieties (see Kayne (1989a; pp. 93-96) for references, also Branigan (1992; p. 42)) and Cocchi (1994; ch. 4), it may be that both of 2a and 2b can be defended. Notice however that 2a, but obviously not 2b, predicts a correlation between rightward agreement and the inversion property, or, in our case, object shift. If in a given variety, the V agrees with a DP that obligatorily appears to its right, we can argue for 2b. If the DP can appear freely also to the left of V, the most accurate analysis is 2a.

We will consider and reject HCA in section 2. As for the choice between 2a and 2b, I argue that both strategies can be defended also in the case of absolute participles. A comparison between word order in absolute participial clauses in Modern and Old Italian, section 3, will show that, whereas the second hypothesis is well founded for the former, the first solution is preferable for the latter. It will become obvious, namely, that word order patterns in Old Italian absolute participial clauses are quite similar to those attested in (4)/(5).

2. MPLT and Belletti (1990)

Belletti (1990) argues that participial agreement with Nominative subjects in Italian Absolute Small Clauses (henceforth: ASC) is the result of DP(S) movement to the Spec of Agr, while the participle raises to the C head of the clause, as illustrated in (9) (where I disregard the Asp Phrase of Belletti (1990)). Verb-raising to C is necessary for Case reasons. This is explained on the assumption that no Tense Phrase is present in ASCs, and that a T feature is generated in C. If the verb incorporates C, marked [+T], Nominative Case will be assigned to the DP in Spec Agr under government from C:

- (8) *Arrivata Maria*, Gianni tirò un sospiro di sollievo (from Belletti; p. 89)
'arrived Maria, Gianni was relieved'

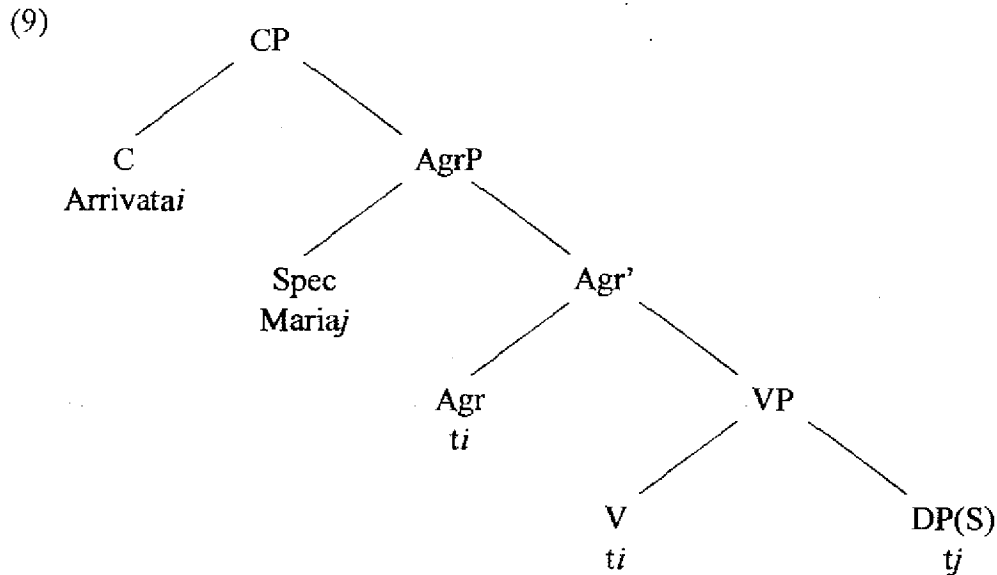

When the participle agrees with a structural object, as in (10), the question is whether agreement is realized in the same way, which would be the desirable conclusion, or through some different device.

- (10) *Conosciuta Maria/me, Gianni ha subito cambiato il suo stile di vita* (p. 89).
 ‘known Maria/me, Gianni has immediately changed his lifestyle’

Belletti argues instead that the S-structure of (10) corresponds to (11), where the object is left in situ:

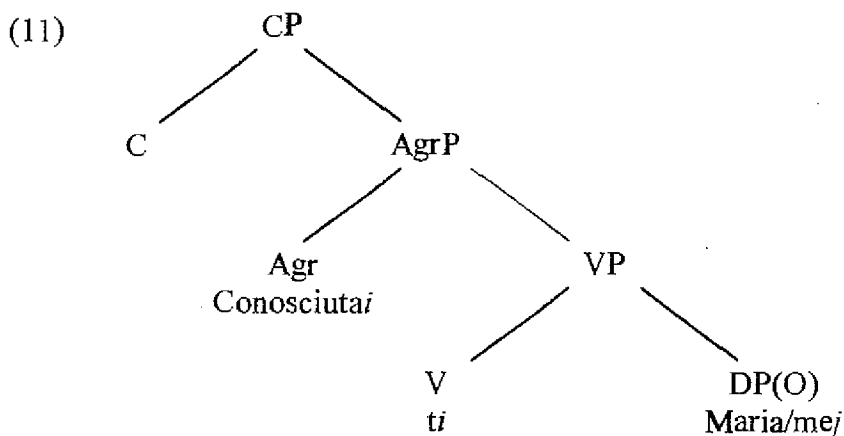

At this point Belletti introduces the hypothesis of agreement between the head and the complement, a marked Case marking strategy, she argues, that makes Accusative available to the object. The first problem she notices is that (10), as well as (8), instantiates verb movement to C, witness the equal ungrammaticality of (12)

and (13), where the participle followed by a lexical argument cannot occur together with a C element:

- (12) *Anche se arrivata Maria, tutti si rifiutarono di partire. (Belletti: p. 99)
'even if arrived M., everybody refused to leave'
- (13) *Anche se conosciuta Maria, Gianni non è cambiato. (p. 110)
'even if known M., G. did not change'

As it seems, then, Comp must be kept free for the verb in both cases. Belletti resolves this by assuming that verb-raising to C applies in overt syntax for reasons of Case marking in (12), and in LF for reasons of Case checking in (13) (Belletti, p. 111).

Theoretical simplicity favours a unified treatment of the transitive and the ergative ASCs⁵, based on V-to-Comp in both cases, and I thereby take the view of Kayne (1989) and Cinque (1990). Trying to reformulate Belletti's proposal in terms of the MPLT, we need to reject the HCA hypothesis for two theoretical reasons:

1. Following the minimalist framework of Chomsky (1992), we can no longer make a distinction between overt movement for Case assignment, and covert movement for Case checking; movement applies for reasons of checking only.
2. The HCA is theoretically motivated in the following way: «...we can speculate that these [SHA and HCA] are the two agreement configurations made available by UG. More specifically, we can suppose that the relation regulating agreement processes is just government by the head or by a head projection.» (Belletti 1990; p. 109). In a theory that tries to eliminate head government, it is necessary to reduce these possibilities to one, since the government relation, intended to capture the two mechanisms in one, is no longer at hand.

⁵ The issue is of course also an empirical one. Belletti adds 'ne'-cliticization facts that would suggest that the object in (i) has remained in situ, on the assumption that 'ne' is extractable only from complement positions.

- (i) Conosciutene [molte_i], ... (Belletti; p. 104)
known of them+cl. many, ...
- (ii) *?Arrivatine [parecchi_i], ... (p. 101)
arrived of them+cl. many, ...

There seems to be some variation among speakers on this point, as Belletti mentions in her f.n. 31. These intuitions are shared by Anna Cardinaletti, but not by Rita Manzini (Class; 1994), Gloria Cocchi and Giuseppina Turano (all p.c.). I have no explanation for this but I will follow the conclusion I take to be theoretically warranted. of course, it cannot be excluded that we are dealing with two distinct grammatical systems

Moreover, whereas the SHA analysis is empirically supported by a variety of facts from Germanic and Romance, the status of the HCA alternative is more obscure; if UG admits for it, we would expect it to be generally available. In order to support the HCA thesis, one might attempt to put forward Old Italian constructions as those in (4) as evidence, but, as we have seen, these are not compelling⁶.

I thus suggest that transitive and ergative ASCs are to be given a unified analysis, based on overt V-to-Comp in both cases. One further problem remains to be addressed: Any account that assumes Case assignment from C to Spec I will have a problem when head government is taken away from the theory. The problem will of course go far beyond the discussion of Italian absolute clauses, but I will concentrate on these.

Consider first that, in the MPLT, Nominative is checked against AgrS into which T has incorporated. Nominative checking would thus involve two features on the verb, AgrS and T, but of course only *one* Case feature on the corresponding DP, Nominative. In Chomsky (1992), Nominative is checked in Spec AgrS, and Branigan (1992) takes the view that Spec T is an A' position⁷. In subsequent work in the Minimalist framework the claim is explicitly made that the Case checking site may vary cross-linguistically: For Jonas (1992), Bures (1993), and Bobaljik & Jonas (1993), the choice of checking site for the DP subject, Spec T or Spec AgrS, is parametrized, and so also for Branigan (1992), who introduces an additional head above AgrS, where Nominative is checked in English⁸. Building on these proposals, we will assume that when two or more features on the verb correspond to the Nominative feature on the subject, only one of these verbal features is crucial for the checking of Nominative and that the other is secondary for purposes of Nominative checking. This means that only one of the features in question will have a Specifier position taken by the subject. In a language where the crucial feature is AgrS and not

⁶ Belletti proposes (i):

(i) *aveva rubati danari* (from Machiavelli, cit. Belletti; p. 144, f.n. 28)
he had stolen [pl.] money

The most interesting evidence should come from a variety where participial agreement is regular, that is, where participles always agree. For Italian, this means going back to the 14th century, as will be shown in Egerland (in prep.). The phenomenon is highly irregular in Machiavelli, and in fact almost absent in many authors contemporary to him. Belletti cites Rohlf's (1969; § 725) who, however, does not give information about this clear difference in use between the 14th century and the 16th century

⁷ In Chomsky (1992), it is actually not clear whether the DP subject passes through Spec T or not, and, consequently, if Spec T is at all projected.

⁸ Prior to minimalism, the idea of parametrization between AgrS and T was explored by Pollock (1989) and others following his proposal, e.g. Junker & Martineau (1992).

T, Nominative checking is illustrated in (14), which is in essence the structure Chomsky (1992) proposes for English, and, I assume, holds also for the Italian finite clause:

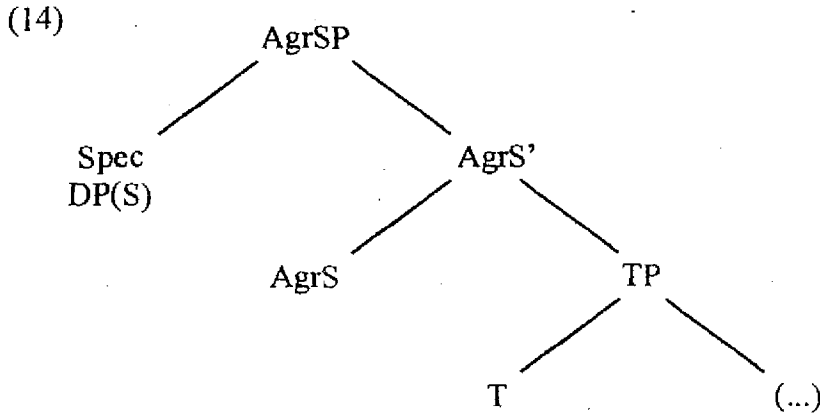

In a language where T is crucial, the DP subject occupies the position of Spec T at Spell-out:

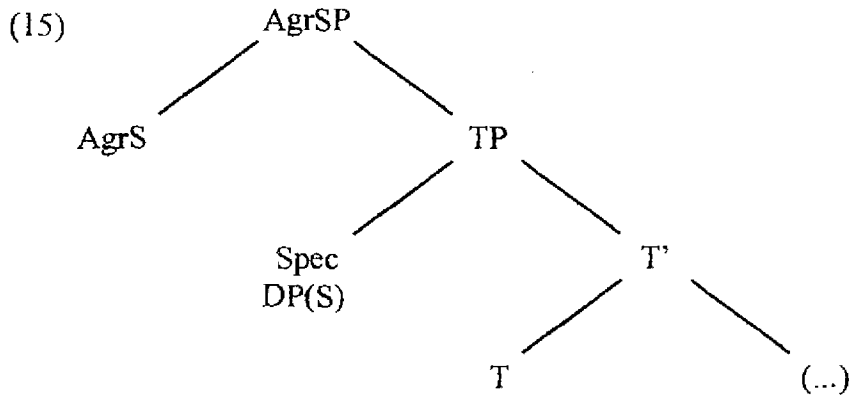

This is what Jonas (1992), Bures (1993) and Jonas & Bobaljik (1993) suggest for Icelandic⁹. Nominative on the DP in Italian, for instance, is checked in the Spec of AgrS and in Icelandic in the Spec of T.

⁹ I will not enter into details of Nominative checking in Germanic which are not crucial for my demonstration. The general idea that the locus of Nominative checking is parametrically decided should be viable regardless of whether the principal feature against which Nominative is checked is C, into which AgrS has been incorporated (in which case we have V-to-Comp) or some of T and AgrS (in which case the V stays in T or AgrS); for recent discussion on V2 and further references e.g. Zwart (1993; 1994); Gärtner & Steinbach (1994); Holmberg & Platzack (1995).

The difference between Modern Italian finite clauses and participial clauses is that T is present in the former and absent in the latter. As T is missing, the V must raise to C in order to make the derivation converge (Belletti (1990)). The idea that the grammar uses C as a ‘reserve’ when T is not available was developed by Madeira (1994) on Portuguese infinitives. It follows from our way of reasoning that the DP subject checks Nominative in Spec AgrS and stops there, as it has no feature to check in Spec C. The V, however, moves first to AgrS and then to C. The participial absolute clause is then, in a sense, the ‘mirror image’ of the finite clause; compare (14) with (16):

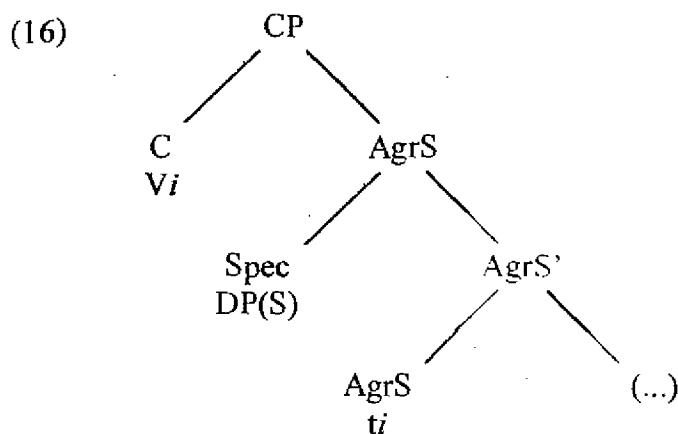

V-raising to Comp follows on general assumptions in MPLT and there is no need to assume head government from C of Spec AgrS

Evidently, the same must be assumed for transitive participial clauses where the DP(O) is marked Accusative. This move is already made by Belletti (1990; p. 111), as Tense is assumed to be necessary for checking of any kind of structural Case, Accusative as well as Nominative. In the absence of a T head, the transitive V will have to raise to C. The theoretic implication is important: it has been argued elsewhere in the literature that Tense is indeed crucially involved in the checking of Accusative Case. The claim is brought forward by Roberts (1987), among others, and repeated by Hoekstra & Roberts (1993). The ‘three-layered Case Theory’ of Watanabe (1993; see above all ch. 4) has the same effect; the checking of Accusative would give rise to the creation of a strong feature that in turn needs checking and deletion in a higher functional projection, Tense.

3. Structure and Derivation of Participial Absolute Clauses.

3.1. The Internal Structure of Participial Absolute Clauses.

Belletti (1990) parts from the assumption that ASCs are CPs, that however do not share all functional projections of a finite CP. The structure she proposes is (17):

(17) [CP C [AgrP Agr [AspP Asp [VP V]]]]

(17) differs from the finite clause structure advocated by Chomsky (1992) in two ways: Only one AgrP is present; in MPLT terms, this Agr could be either 'S' or 'O', meaning that either Accusative or Nominative can be assigned inside the participial CP, but not both. Furthermore, the clause has no Tense projection.

In order to deal with data that will be presented below, we prefer instead an approach to participial small clause structure that makes them as similar as possible to that of finite clauses. There is independent motivation for this move; in recent work, Kayne (1993) shows that participial clauses in the compound tense in certain Italian varieties, display properties that reveal the presence of both a T and an AgrS category inside such clauses. The choice of auxiliary is sensible both to the tense of the finite verb, and to the number specification of the subject, which suggests that AgrS and T are indeed present, though 'inert' in the sense that they do not check Nominative on the subject. That participial clauses host a richer functional structure than indicated above is argued also by Cinque (1994) on the basis of adverbial distribution facts in Italian.

Relying on Old Italian data, it can be shown that ASCs may host a full set of functional projections, as Kayne (1993) argues for the participial clause in the compound tense. Starting with the AgrS node, it has been noted (Manzini, Class; 1994), that transitive ASCs with two realized arguments are not totally excluded in Modern Italian:

(18) Restituiti *io* i libri, ...
'returned I the books, ...'

For Manzini, the acceptability of (18) may be a matter of register. Old Italian data are quite clear on this point, as constructions of the type illustrated in (19) are very frequent¹⁰:

- (19) a. **Fatte le comandamenta la Fede Giudea, ...**,
'Made_[f.pl.] the commandments the Jewish faith,
cominciò la Fede Cristiana a signoreggiare tutto 'l mondo...
began the Christian faith to rule all the world'
(Vizi; XLII)
- b. **Vinta la Fede Pagana tutta la terra d'oltremare ...**,
'Won_[f.sing] the Pagan faith all the land beyond the sea
colse baldanza sopra la Fede Cristiana ...

¹⁰ As some of the constructions reported in the texts are quite complex, the crucial portion of the sentence is put in bold face in order to facilitate the reading.

(she) caught boldness over the Christian faith...

(Vizi; XLVII)

c. Racquistata e rivinta la Fede Cristiana

'Conquered_[f.sing] and re-won_[f.sing] the Christian faith

tutta la terra di qua da mare ...

all the land on this side of the sea'

(Vizi; LIII)

d. ed Enea presa la lancia, ...

'and Enea taken_[fem.sing] the lance, ...'

(Fatti; LVII)

e. e per comandamento di lei, Dioneo preso un liuto e la Fiammetta

'and on her commandment, Dioneo taken_[m.sing] a lute and Fiammetta

una viola, cominciarono soavemente una danza a sonare...

a viola, (they) began sweetly a dance to play'

(Dec; Intro)

f. ... ricevuta ser Ciappelletto la procura e le lettere favorevoli del re ...

'received_[f.sing] ser Ciappelletto the proxy and the favours of the king'

(Dec; I:1)

We will turn to the question of word order in paragraph 3.3.. From (19a)-(f) we conclude that two separate Agr nodes were present in Old Italian ASCs, in order to check Nominative and Accusative. The structure of ASC in Old Italian must then at least be (20):

(20) [AgrSP AgrS [AgrOP AgrO [VP V]]]

where I continue to disregard the possibility of an Aspect Phrase.

Recall that Belletti (1990) argues that ASCs are CPs because they can be introduced by a complementizer element. Old Italian was strikingly more liberal than Modern Italian on this point. Old Italian ASCs could host a variety of elements in the Comp field; complementizers as in (21a) and (21b), and relative expressions of various kinds as in (21c)-(21e)¹¹:

(21) a. ... dicono li soprascritti savi che, **bene che quelli cotali uomini**

'the above mentioned learned say that, in spite those men

diventati animali, ... la mente dentro rimaneva loro umana, ...

¹¹ In (21c), the introducing preposition 'per' has been deleted, cf. the English gloss. Example (21d), from the *Esposizioni*, is reported by the editor Giorgio Padoan.

*become*_[m.pl.] *animals, ... their mind inside remained human*'

(Fatti: XXVII)

- b. **Per ciò che levatesi tutte e lui invitato, in una fresca corte il menarono ...**
*'For which reason stood*_[f.pl.] *up everyone and him invited*_[m.sing.],
in a fresh court they brought him'

(Dec; I:10)

- c. **La qual cosa molti de' vicini avanti destisi e levatisi ...**
*'For which reason many of the neighbours before woken*_[m.pl.]
*and stood*_[m.pl.] *up*'

(Dec; II:5)

- d. **Per la qual cosa Eva mangiato del frutto proibito, e datone ad Adamo,**
*'Because of this Eve eaten*_[m.sing.] *of the prohibited fruit, and given*_[m.sing.]
incontanente s'apersero gli occhi loro, e cognobbero che essi erano
ignudi...

thereof to Adam, immediately there eyes opened and they recognized that
they were naked'

(Espos; IV (45))

- e. **La quale il giudice menata con grandissima festa a casa sua, ...**

*'Whom the judge taken*_[fem.sing.] *with great joy to his house*'

(Dec; II:10)

It is of some interest to notice that the participial clause could take on the function of an embedded interrogative. For cases as (21f) and (21g), the term 'absolute' is not quite appropriate.

- (21) f. ... senza sapere chi la moglie tolta gli avesse o **dove portatala.**
'without knowing who the wife had taken from him or where
*taken*_[fem.sing.] *-her*'

(Dec; II:10)

- g. ... fece dire a Salamone come ella era e **perché quivi venuta.**

*'he made Salamone say how she was and why here come*_[f.sing.]'

(Trec; II)

(21a)-(21g) clearly show that Old Italian ASC was CP, as the modern equivalent:

- (22) [CP C [AgrSP AgrS [AgrOP AgrO [VP V]]]]

The above data force a further move: As we have mentioned, overt complementizers cannot occur with overt Nominative or Accusative arguments in the Modern Italian ASC:

(23) Anche se arrivata, Maria ...
'Even if arrived, Mary ...'

(24) *Anche se arrivata Maria, ...
'Even if arrived Mary, ...'

Recall that this is imputable to the necessity of V-raising to Comp, which, in turn, is forced in the absence of a T head. If, then, in Old Italian, both Nominative and Accusative Case are available in ASCs in spite of the presence of other elements in CP, we deduce that Tense is present elsewhere in the clause, and that the structure of an Old Italian ASC is indeed (25)¹².

(25) [CP C [AgrSP AgrS [TP T [AgrOP AgrO [VP V]]]]]

The assumption that the Old Italian ASC had an active T head can account for some of the fundamental differences between Old and Modern Italian ASCs. As mentioned, Old Italian admitted a variety of Comp-elements, among which Wh-expressions. This would follow from the presence of T if, as claimed by Rizzi (1991), Infl (in our case T) is the locus of Wh-features which are raised to Comp. Modern Italian ASCs are correctly predicted to be more restrictive on this point, if the T parameter has a negative value.

Recall, moreover, that Modern Italian ASCs cannot host negation:

(26) *Non arrivata Maria, ... (Belletti (1990))
'not arrived Maria, ...'

(27) *Non arrivata, Maria ...
'not arrived, Mana ...'

Belletti explains this, building on a suggestion of Zanuttini (1991), as due to the absence of Tense in ASC. The structure proposed in (25) predicts instead that negation should have been possible in Old Italian ASC, and such data are indeed attested.

(28) ... **non spaventato dal recente peccato da lui commesso**,
'not scared by the recent sin by him committed'

¹² A diachronic fact may be relevant: recall that principles ruling over the tense and aspect system in modern Italian do not yet apply in the 14th century, that have not totally abandoned patterns of (classic and vulgar) Latin. Crucially, as 'amatus sum' can mean both 'I am loved' and 'I have been loved', the participial clause can be assumed to carry a temporal specification independently of the main clause. In what way such considerations correlate with the syntax of participial clauses in Old Italian remains an open question. (see e.g. Ageno (1964), Tekavcic (1972; XIII, §§ 628-630), and Bertinetto (1986)).

con le mani ancor sanguinose allato le si coricò...
with the hands still bloody beside her he laid down
(Dec; II:7)

- (29) ... **mai non riconosciutala**, (...)
'not ever recognized her_[clitic]'
lei nelle braccia ricevuta lagrimando teneramente basciò.
her in his arms received crying he kissed tenderly
(Dec; II:6)

I take this to indicate that the structure of Old Italian indeed hosted a Tense head, which is no longer present in Modern Italian, or, alternatively, is still present but in some sense 'inert'.

There is another curiosity about 14th century syntax that may have relevance for our case and deserves comment: Absolute constructions in 14th century texts are not unfrequently introduced by a conjunction, 'e' ('and') or 'ma' ('but'), and appears to be coordinated with finite structures¹³.

- (30) **Ma pure stato un pezzo**, ed e' disse: ...
'but still stayed_[participle] for a while, and he said_[finite]: ...'
(Pec; II:2)

- (31) **E andaronsene in camera, e posti a sedere**,
'and they went_[finite] to the room, and sat_[participle] down,
e ecco venire due donzelle co vino
and see come_[infinitive] two girls with wine'
(Pec; IV:1)

Coordinations of this kind would in modern use be awkward or excluded. The assumption that the Old Italian participial clause carried its own independent Tense specification might contribute to our understanding of the phenomenon; the language user that coordinates absolute participial clauses with finite ones, treats the former as if they were, if not equal to the latter, at least comparable. As usual, it is difficult to tell the difference between what can be taken to be part of the grammatical system,

¹³ See, among many others, Sorrento (1950; pp. 25-91), and Ageno (1964; chapters 10 and 14), who however concentrate their discussion on coordination main clause-subordinate and finite V-gerund. The phenomenon, often referred to as 'parahypotax', thus extends beyond the cases mentioned in the text; a circumstance which however does not exclude that our way of reasoning is on the right track. Examples (30) and (31) from the *Pecorone* are both noticed by the editor Enzo Esposito.

on the one hand, and written language artifacts, on the other. The following paragraph discusses some additional problems linked to this.

311 In some of the above examples, and others that follow, it is possible to imagine a different analysis (more coherent with Modern Italian) quite simply replacing the commas. Consider a case like:

- (32) ... e io **messigli in una mia cassa** senza annoverare, ivi bene a un mese
'and I put_[+Agr] them_[cl] in a box without counting, a month later
trovai ch'egli erano quattro piccioli piu che non doveano.
I found that there were four 'piccioli' more than there should be'
(Dec; I:1)

The construction is grammatical for a Modern speaker, if a comma is added after the subject 'io' (e io, **messigli in una** ... annoverare, ...) ¹⁴. Considerations of this kind may be relevant for some of the cases, as the reader already has noticed (in (21b) but definitely not in (19e) or (21a) or (21d), for instance). However, only a small part of the data can be 'saved' in this manner and it is quite clear that constructions of the type in (32) were perfectly grammatical also with a reading that makes 'io' belong to the participial clause. A large part of those complex structures that traditional analysis refers to as 'anacolutes', or similar, obviously follow patterns different from modern Grammar, but they do so in a quite systematic fashion and do not escape a principled explanation. Consider (33):

- (33) Erano i due angeli, quando alla casa di Lot pervennero,
'The two angels were, when they came to the house of Lot
in forma di due spezosissimi giovanetti, **li quali da' Sogdomiti veduti**,
in the shape of two beautiful youngsters, which by the Sodomites seen,
incontanente corsono alla casa di Lot, adomandando d'aver questi giovani.
(they) immediately ran to the hous of L., asking to have these youngsters'
(Espos; XI (36)) ¹⁵

The construction is curious for the modern speaker that tends to interpret the relative pronoun, 'li quali', as the subject of the finite V 'corsono' ('they ran'), which, of course, it is not. The modern grammar favors an analysis of the kind 'i quali, visti dai sodomiti, corsono alla casa di Lot'. As the commas of the texts indicate, what we have here is two coordinated main clauses, 'the angels were...' and 'they ran immediately...',

¹⁴ See Ageno (1964; ch. 14) for some discussion on the problem of punctuation.

¹⁵ Noticed by Giorgio Padoan, as (21d) above.

and the string 'li quali da' Sogdomiti veduti' is an absolute clause embedded under the second main clause. The subject of 'corsono' is a null pronominal element and as such free in reference. This reading of (33) is coherent with the observation that relative pronouns could generally introduce absolute participial clauses.

I conclude from the evidence presented in paragraph 3.1. that the 14th century ASC had, at least, the set of functional projections illustrated in (25). I assume the structure in (25), and proceed with the discussion of word order.

3.2. Verb-Raising

In the presence of an overt complementizer or other CP-elements, word order in the Old Italian ASC may still be (Comp-)SVO. The natural conclusion is that the participial verb in Old Italian absolutes did not move as far as to C, but stayed in a lower position, that I take to be Agr ('S' if a Nominative subject is present, and 'O' in the presence of an Accusative object). This conclusion already follows on the assumption that there is an (active) Tense head in the structure. The structure of an ASC hosting an ergative V and a Nominative subject, would thus be (34):

(34) $[_{CP} C [_{AgrSP} DP(S)] V_i [_{TP} t_j t_i [_{VP} t_i t_j]]]$

In Old Italian ASCs, the V did not obligatorily appear in first position. Apart from the complementizer, both DP arguments and prepositional material could precede the verb, witness (35a) and (35b), schematically expressed in (36a) and (36b) (compare also, for instance, (21c) above).

- (35) a. (...) e con festa da lei **preso commiato**, si parti.
'and [with joy] [from her] taken farewell, he went away'
(Dec; I:10)
- b. ... con senno e con ordine **l'ufficio commesso**,...
[with sense and with order] the office accomplished
(Dec; II:8)

- (36) a. $[_{CP} (PP) (PP) \text{participle } DP(O)...]$
b. $[_{CP} (PP) (PP) DP(O) \text{participle... }]$

This is of course expected under present assumptions; if the verb did not move as far as to C, but to AgrS, prepositional or adverbial material could appear to the left of the participial V adjoining to AgrS, if adjunction is admitted, or as the Specifiers of some recursion of AgrS (cf. Belletti (1990); Kayne (1994); Cinque (1994)).

There is a further reason to believe that V-movement in Old Italian ASCs did not target C. Recall that (37), formed out of passive V + an Agentive by-phrase, is ungrammatical in Italian (Belletti (1990); p. 89¹⁶):

- (37) ***Salutata Maria da Gianni**, tutti uscirono dalla sala.
'greeted Maria by Gianni, everybody went out of the room'

The problem is to explain why in (37), 'Maria' cannot receive Nominative, as it does elsewhere in Modern Italian ASCs. Belletti (p. 110) suggests that this depends on a Case conflict: The V in (37) needs to reach C in order to give Nominative. Being passive, however, the participial ending is argumental and carries Accusative. (37) is ruled out because of the presence in C of both Nominative and Accusative features¹⁷.

Under the above assumption that the participle did not reach C, (37) should have been grammatical in Old Italian (with Nominative on 'Maria'). This seems to be correct, as the constructions in (38) were fairly frequent¹⁸:

- (38) a. ..., **commendata da tutti la novella di Neifile**, ella si tacque...
'commended by everybody the novel of Neifile, she fell silent'
(Dec; I:3)
- b. **Ma questo da' ciciliani conosciuto**, subitamente egli
'But this (=he) by the Sicilians recognized, immediately he
e molti altri amici... furono per prigionieri dati...
and many other friends were given as prisoners'

¹⁶ Also in this case, we are presumably dealing with a general property of Old Italian grammar that is exceptionally attested in contemporary language and in particular contexts. A couple of examples reported in Bertuccelli Papi (1991; p. 595) are obviously stylistically marked. For further evidence from ancient texts, see e.g. Herczeg (1972; pp. 193-194).

¹⁷ This explanation can, as far as I can see, be upheld also after the reformulation of Belletti's system that we proposed in section (2). Crucially, we assume that the Case conflict arises only when Accusative has been assigned to the participle, i.e. when the participial morphology is argumental. The alternative analysis of (37), where 'Maria' carries Accusative, is independently excluded on several grounds (Belletti p. 115).

¹⁸ Gunnarsson (1995) argues that the by-phrase in ASC is grammatical in Spanish (p. 144), and that Spanish ASCs do not instantiate V-to-Comp (pp. 152-154). This seems to be in line with my demonstration, but, as declared in the Introduction, a further investigation on Spanish data is beyond the aim of this paper. By the way, Gunnarsson's example (on p. 144), is of a high register, not very different from the one cited by Bertuccelli Papi (1991; p. 595).

(Dec; II:6)

c. **Fatta adunque la concession dal soldano a Sicurano,...**

'Made_[fem.] thus the concession by the sultan to Sicurano'

(Dec; II:9)

Evidently, this turns into an indirect argument that an active T head is present inside the participial clause, and that V-to-Comp, consequently, does not apply.

3.3. DP-Movement in Old Italian ASCs

Notice that agreement with the DP ('O' if the Verb is transitive, 'S' if ergative) was obligatory as in Modern Italian. If we are right in claiming that AgrO could license object pro (cf. section (1) above), the inversion property attested in participial complements to 'have' should also be present in ASCs. This is indeed confirmed, since both (39) and (40) are frequently attested.

(39) Part._[+Agr]-DP(O), ... 'Written the letters, ...'

(40) DP(O)-Part._[+Agr], ... 'The letters written, ...'

(41) a. ... **serrata la cella con la chiave...**

'locked_[fem.] the cell with the key'

(Dec; I:4)

b. ... il re di Francia, **molte triegue fatte con gli alamanni, morì...**

'the king of France, many truces made with the Germans, died'

(Dec; II: 8)

The structure of (41a)/(41b) corresponds then to the trees given in (42)/(43) (additional functional projections are left out for reasons of space):

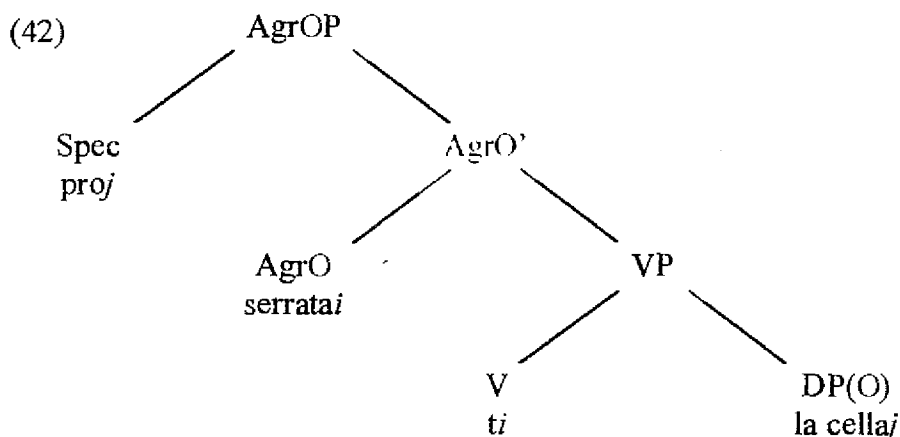

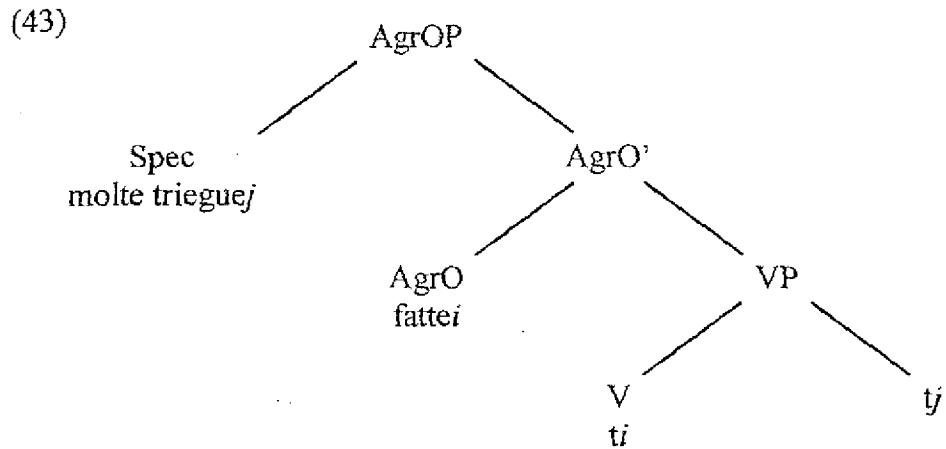

The same must be true for Nominative subjects in Old Italian ergative ASCs, since Old Italian AgrS licensed null subjects¹⁹. Consider again (21a) and (21b), here abbreviated:

- (21) a. Per ciò che **levatesi tutte**... (Dec; I:10)
 b. ... **molti de' vicini** avanti **destisi** e levatisi ... (Dec; II:5)

In these cases, the same analysis will apply to AgrS:

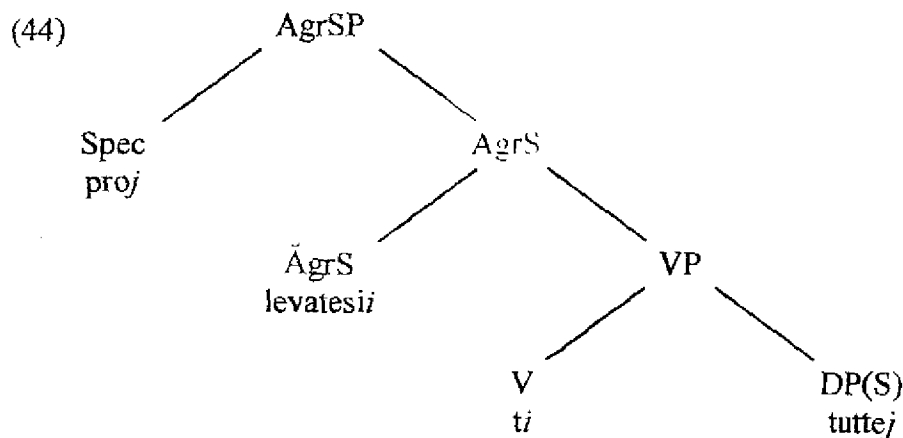

¹⁹ Not surprisingly, Bertuccelli Papi (1991; p. 600) has an example from contemporary literary language also in this case. Notice that the example she cites instantiates a preposed pronominal subject: 'lei uscita'; DPs in preverbal position in 14th century texts are often 'heavier'. I take it our way of reasoning holds for this exception as for the previously cited ones; compare examples (18)-(19) in the text and footnotes 2 and 16.

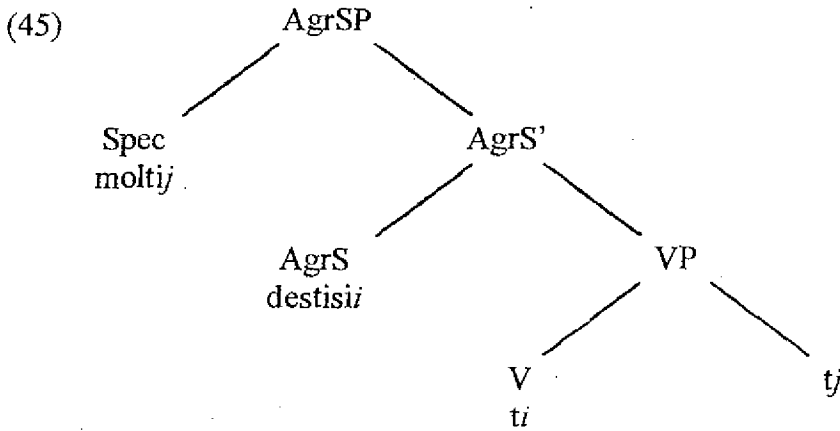

We have predicted various other possibilities. As can be seen from (19a)/(19b), here repeated, the subject of a transitive ASC can appear to the right of the object (V-DP(O)-DP(S)) and between the object and the participle (V-DP(S)-DP(O)).

- | | | |
|---------|---|---|
| V | O | S |
| (19) a. | Fatte le comandamenta la Fede Giudea,... | |
| | ‘Made _[f.pl.] the commandments the Jewish faith,...’ | |
| V | S | O |
| b. | Vinta la Fede Pagana tutta la terra d’oltremare..., | |
| | ‘Won _[f.sing] the Pagan faith all the land beyond the sea,...’ | |

Both (19a) and (19b) are expected under this analysis. As indicated, I take it the V raises to AgrS in all cases. In (19a) I assume that DP(O) raises overtly, and DP(S) stays in situ:

- (46) = (19a) by Spell-out:
 [... [_{AgrSP} proj Vi [_{TP} tj ti [_{AgrOP} DP(O)k ti [_{VP} DP(S)j ti tk]]]]]

In (19b), on the other hand, the V has raised overtly to AgrS, whereas both DP(S) and DP(O) remain in situ:

- (47) = (19b) by Spell-out:
 [... [_{AgrSP} proj Vi [_{TP} tj ti [_{AgrOP} prok ti [_{VP} DP(S)j ti DP(O)k]]]]]

As indicated in (46) and (47), arguments that stay in situ are always doubled by an expletive pro that moves in overt syntax. A third combination, SVO is trivially predicted if all elements move in overt syntax.

Interestingly, though, we have not attested SOV, OVS or OSV, unless one of S or O is a relative pronoun. The correct generalization seems to be that, in a structure with two lexical arguments, S and O, the object cannot appear to the left of the participle V. This is consistent with my demonstration; if there is a Nominative

subject, the V needs to reach AgrS and the object must then appear to its right, or lower than the V.

Summing up the analysis of paragraphs 3.2.-3.3., the correlation between rightward agreement and 'free' word order appears to be solid. 'Free' word order is, as above, the informal indication of the option for a DP to move overtly or stay in situ being doubled by an expletive element. As a consequence, I assume both expletive Nominative chains and expletive Accusative chains. Checking of both Accusative and Nominative Case is overt in both Old and Modern Italian ASCs, but Old Italian ASCs generally admit for two lexical arguments.

Notice, finally, that the comparison between Old and Modern Italian data might give support to Watanabe's (1993) layered Case-theory, or some version of that idea (the reader is referred to his discussion). If the checking of structural Case in a functional projection must be followed by an additional checking process in a higher one, and if the Old Italian ASC has both T and C (each dominating an Agr node) whereas the modern ASC only C, the expected difference between the grammars is that in the Old ASC two structural Cases could be checked, but in the modern one only one structural Case. In my demonstration, I have avoided the formalism of Watanabe's proposal, but do not exclude that it may be pursued. Under all circumstances, the study of Italian participial clauses of both periods lends support to the idea that Tense is indeed relevant for the checking of both structural Cases.

3.4. Old Italian Gerundival Clauses

We have followed Belletti (1990) and Kayne (1989), in assuming that the V-to-Comp hypothesis of Rizzi (1982) applies to Modern Italian ASCs. We have argued that Old Italian ASCs do not instantiate V-to-Comp and that word order patterns are to be analyzed in terms of a pro strategy. Which alternative we chose may of course be relevant not only for participial small clauses, but for non-finite absolute constructions in general. Interestingly, the absolute gerund follows the same patterns as the participle. Whereas, in Modern Italian, the V in gerundival absolute constructions must be in initial position, Old Italian admits word order SV (48) and OV (49).

(48) ... **Andreuccio putendo forte**, disse l'uno...

Andreuccio smelling badly, one of them said...

(Dec; II:5)

(49) ... **ella, ogni avversità trapassata dimenticando**, divenne lieta...

'she, all troubles past forgetting, was happy'

(Dec; II:7)

When the object is some kind of relative pronoun, we attest both OVS (50) and OSV (51). Even if it is possible to assume V-to-Comp in (50), it is not so in (51):

- O(rel) V S
(50) **La qual cosa veggendo Stecchi e Marchese...**
Which thing seeing Stecchi and Marchese
(Dec; II:1)

- O(rel) S V
(51) **Il che la donna veggendo, ...**
Which the woman seeing, ...
(Dec; II:5)

Trivially, we of course also find constructs that respect modern word order.

Crucial differences in word order patterns between Old Italian and Modern Italian ASCs are thus attested both with participial and gerundival absolutes. The conclusion that Old Italian did not have V-to-Comp in absolute constructions seems to be essentially correct²⁰.

4. *Argumental pro and the Problem of Recovery*

What we have assumed in our discussion is an expletive small *pro* that can fill the grammatical function of both object and subject. As the element assumed is expletive, there has been no need, so far, to enter the question of recovery; expletive *pro* does not need to be recovered (Rizzi 1986; section 6). The question must be addressed, however, as there are reasons to believe that also argumental *pro* was possible in the Old Italian ASC. It is somewhat unclear to what extent Old Italian was actually different from Modern Italian on this point. Belletti (1990; p. 120) gives examples where the context gives the necessary information about the content of the null subject:

- (51) *I ragazzi sono partiti in ritardo e, arrivati a casa, non c'era più nessuno.*
'the kids left late and, arrived home, nobody was there'

In the 14th century, null subjects of ergative ASCs are not necessarily coreferential with the main clause subject, but the antecedent is usually present in context. Very often, the subject of the ASC is plural and includes the singular subject of the

²⁰ So far, we have assumed that Tense can be syntactically absent or present. The data call for a more refined analysis, distinguishing not only between the absence or presence of Tense but, say, between different degrees of 'activity' or 'strength', given, for instance, that modern absolute gerundives can host negation. Gunnarsson (1995; pp. 142, 153) argues along these lines.

main clause; the subject in (52) and (53) is one of the persons referred to in the participial clause:

(52) E **ismontati e assettati** a sedere, disse: ...
'and dismounted_[pl.] and seated_[pl.], (she) said'
(Vizi; XIV)

(53) E a lui **rivolti**, disse l'uno: ...
'and to him turned_[pl.], one [of them] said'
(Dec; II; 5)

Somewhat more awkward to the modern speaker is (54), where two absolute constructions precede the main clause; the null subject of 'piaciuta' is coreferential with the object of the gerundival small clause, but absent from the main clause.

(54) Avendo veduta a una festa una **bellissima donna**...
'having seen at a feast a beautiful women
e **piaciutagli sommamente**, non altrimenti che un giovinetto
and pleased_[sing.f.] him very much, non differently from a youngster
quelle [le amoroze fiamme] nel maturo petto ricevette...
those in his mature breast (he) received'
(Dec; I:10)

A preliminary conclusion may be that participial agreement can recover a small pro, despite the lack of 'person' features (contrary to the claim of Rizzi (1986, section 6)). This conclusion faces a problem, since, in such a case, we would expect the participial Agr to be able to recover both null subjects and null objects. (52)-(54) are all cases of subject pro marked Nominative, licensed by AgrS. In the 14th century material, we do *not* find examples of the kind

(55) Conosciuta_i pro_i Gianni, ...
'known_[f. sing.] - John, ...'

where the participial AgrO recovers a null object. In a case as (56), pro corresponds to the internal-argument of 'prendere' ('take')

(56) E **preso, così fatto, da Marchese e da Stecchi**.
'And taken_[sing.m-f] in that way, by M. and by S.
verso la chiesa si dirizzarono...
towards the church (they) went'
(Dec; II:1)

but the presence of the agentive by-phrase, 'da M. e da S.', is a clear sign that the participle is passive (compare (38) above) and that the pro in question is still

Nominative, licensed by AgrS. The participle in (56) agrees with the null element in masculine singular. More interestingly, a null subject (disjoint in reference from the main clause subject and hence not controlled) is allowed also with active transitive participles, where the participle agrees with the DP object:

- (57) Martellino... sopra santo Arrigo fa vista di guerire e,
'M. on saint A. pretends to be cured and
conosciuto il suo inganno, è battuto e poi preso.
known his bluff, (he) is beaten and then arrested'
= 'As *they* had understood his bluff (as his bluff had been known), *he* was beaten'
(Dec; II:1)

- (58) Egli, fatto di chiaro, mostrando di venire di più lontano,
'He, made clear day, showing to come from far away,
aperte le porte, entrò nel castello...
opened the gates, entered the castle'
= 'As *they* had opened the gates (as the gates were opened), *he* entered the castle'
(Dec; II:2)

(57) and (58), where the null subject is arbitrary, are perhaps not excluded in Modern Italian. Clearly different are the cases of (59) and (60), where the null subject is specific²¹:

- (59) **Risposto alla Prudenzia a tutte le sue adomandagioni...**
'answered to Prudence to all her questions
disse: - I gliuolo mio...
she said My son...
= 'As *I* had answered, *she* said...'
(Vizi; LXIX)

- (60) **Fatto questo**. Sibilla lo menò allo 'nferno
'done this, S sent him off to the Hell'
= 'As *he* had done this, *she* sent him...'
(Fatti; XXV)

²¹ There is a clear contrast between these and the examples judged ungrammatical by Belletti (1990; p. 121).

Consider also a slightly more complex case as (61):

- (61) **Ricevuto per fedele da la Fede Cristiana,**
'received_[sing.m.] as a believer by the Christian Faith,
e giurate le sue comendamenta, n'andammo a letto
and sworn_[pl.f.] her commandments, we went to bed'
= 'As I had been received... and as I had sworn..., we went to bed.'
(Vizi; XIX)

Here, two transitive participial clauses (the first passive, the second active) precede the finite clause. The null subject of the first is coreferential with the null subject of the second, but they are both disjoint in reference from the subject of the main clause.

The conclusion that participial Agreement recovers argumental *pro* is probably not correct. Accusative marked argumental null objects are not attested; Nominative marked argumental null subjects are attested regardless of whether the participial V agrees or not. Furthermore, argumental subject *pro* is recovered also with absolute gerunds:

- (62) ... *aspettando la donna che Buondelmonte venisse,*
'waiting the woman that B. would come
e non venendo, cominciò aver paura...
and not coming, (she) began to fear'
= 'As he did not come, she began to fear'
(Pec; II: 2)

Summing up, we are left with the following conclusions:

1. Our discussion on word order in Old Italian participials has brought us to conclude that both AgrS and AgrO license *pro*; we are assuming both object and subject *expletive pro*.
2. *Argumental* object *pro* is not attested and I take this to indicate that it could not be recovered.
3. *Argumental* subject *pro* is attested and, hence, recovered but not by agreement; argumental subject *pro* is allowed regardless of whether the participle agrees or not.

Some alternative recovery strategy must be at hand. I have no precise claims to make as for the nature of this mechanism or why it is available only to recover a null subject but not a null object. Notice that various approaches to recovery will have a problem: Cole (1987), developing ideas of Huang (1984; 1989), assumes the existence of two groups of languages: in the first, a Generalized Control Rule (GCR)

applies to both PRO and pro, in the second, GCR applies only to PRO. In this second group, where we find Imbabura Quechua, Korean and Thai (Cole (1987)), null object pronominals are permitted without identifying agreement on the verb. The analysis of Cole makes explicit the claim that there exists a category of languages of the world where null pronominals need only to be Case marked, and where no additional requirement on identification is to be met²². Given the properties of Old Italian, however, this language should presumably be included in the first group, as Modern Italian (Old Italian had past participial agreement). Under all circumstances, it is unclear why Nominative pro but not Accusative pro could be recovered.

Farrell (1990), discussing Brazilian Portuguese (see also Bianchi & Figueiredo Silva (1993) on the same topic), attempts a different solution. In the absence of identifying Object Agreement in Brazilian Portuguese the claim is that intrinsic, non phonetically realized features on an Agr head may suffice for identification. Once again, the proposal contributes little to our understanding of why null argumental subjects are attested (even in the absence of identifying agreement features) but not null argumental objects (not even in the presence of identifying agreement features). Furthermore, Farrell's claim (p. 344) that pro, in the absence of ϕ -features on its licensing head, is intrinsically specified third person, does not apply to our case; the null subjects of (60) and (62) are first person, for instance.

I conclude that the recovery problem, seen in the light of some current approaches, remains unresolved and I leave the issue for future research.

5. A Note on the pro Theory of Rizzi (1986) and Concluding Remarks

We have crucially assumed that word order differences between Old and Modern Italian are imputable to the fact that AgrO licenses pro in the former but not in the latter. As the reader will have noticed at this point, there is a possible conflict between this claim and the object pro hypothesis of Rizzi (1986). I believe that eventual problems may be avoided if Rizzi's hypothesis is adapted to the MPLT framework and I will briefly suggest how, without going into the analysis in depth. There are, roughly, two possibilities to consider:

²² The same conclusion is essentially reached by Sigurdsson (1992) dealing with Old Icelandic, followed by Sprouse & Vance (1993) on Old French. The identification, or recovery, condition on object pro proposed for these languages is (i):

- (i) pro is identified by free coindexing with any NP in preceding discourse.
- (i) states what seems to be a property of overt pronominals in general (as long as principle B of Binding Theory is respected) and boils down to a claim that there is no particular requirement on identification. (i) has, in any case, little to say for our Old Italian data, as the asymmetry between null subjects and null objects remains unexplained.

Take some of the crucial data and the structure proposed by Rizzi (1986):

- (63) Questa musica rende _ allegri (Rizzi (1986; p. 507))
'This music renders _ happy'
- (64) Il comportamento di Gianni lascia _ sconcertati/stupiti/meravigliati. (p. 507)
'John's behavior causes-to-remain _ disconcerted/puzzled/astounded_[pt.]'
- (65) Questo esercizio mantiene [_ sani]. (p. 533)
'This exercise keeps healthy_[pt.]'

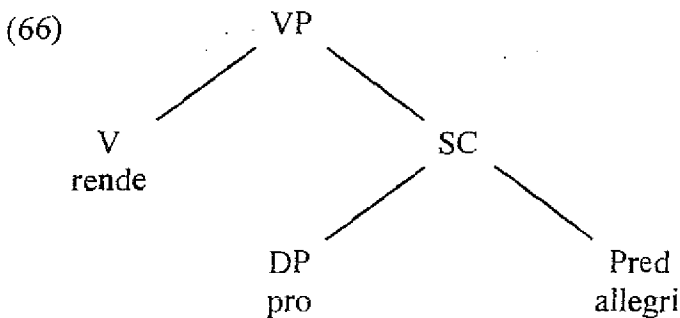

In MPLT, V cannot license *pro* through government in (66) but this problem is only apparent. What we can suppose is that the small clause contains an Agr head which licenses (and recovers) *pro* in its specifier²³. Recall, furthermore, that Chomsky (1992) suggests a distinction between participial agreement, AgrO, and adjectival agreement, AgrA. When Rizzi's model is translated into MPLT terms, we can make the claim that in Modern Italian object *pro* is licensed and recovered by AgrA. Instead of (66), the structure (67) can be assumed, following e.g. Chomsky (1992) and Cardinaletti & Guasti (1992):

²³ As far as I can understand, Rizzi's assumption on a complex predicate (section 5), if needed, must be viable also in the MPLT frame.

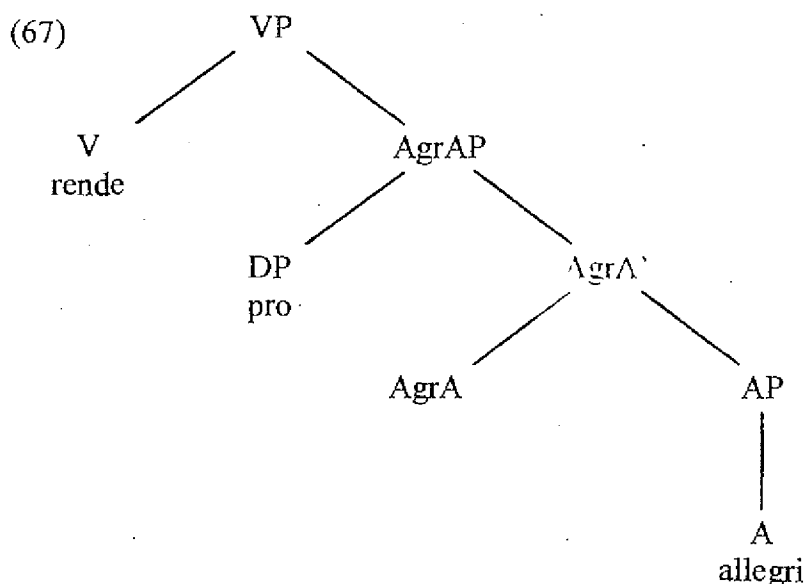

The proposed structure covers other relevant data: expletive *pro* is licensed in the Spec of AgrA in (68a) and (b):

- (68) a. Gianni ritiene [*pro* probabile [che Mario venga]]. (Rizzi (1986; p. 527))
 'John believes likely that Mario comes'
 b. Il tuo comportamento ha reso [*pro* improbabile [che Mario venga]].
 'Your behavior rendered unlikely that Mario comes'

The same analysis carries over to cases of inversion of the small clause subject:

- (69) a. Ritengo [suo fratello più intelligente] (p. 529)
 'I believe his brother more intelligent'
 b. Ritengo [_ più intelligente suo fratello]
 'I believe more intelligent his brother'

Assuming the licensing head to be AgrA and not AgrO, we have taken care of (63)-(65) and (68)-(69). The occurrences of *pro* in (70)/(71) may seem more problematic:

- (70) Il bel tempo invoglia a restare. (p. 503)
 'The nice weather induces _ to stay'
 (71) Un generale può costringere _ a obbedire ai suoi ordini.
 'A general can force _ to obey his orders'

We have therefore to consider a second possibility: What we have assumed above, building on ideas of Belletti (1990), Roberts (1987) and Watanabe (1993),

perhaps offers a way to circumvent also this difficulty. Licensing of *pro* in (70)/(71) may not depend (exclusively) on AgrO but on T. If T is indeed involved in Accusative checking, it may count as a licensing head, for instance, when AgrO has incorporated into it. The licensing head would then be [_T T° AgrO]. Furthermore, it may be that the licensing condition makes reference not only to a licensing head but also to some specification of the head; suppose the licensing head is T when [+generic] or, perhaps, [-specific]. Intuitively speaking, the restriction on the time reference to which these constructs are subject (Rizzi (1986; p. 504), also Authier (1992)), might come out more naturally on such an assumption. Having said this, we are now in a state to draw the last conclusions of the analysis:

Our initial claim was that the observed differences between Old and Modern Italian follow on two assumptions:

1. In Old Italian absolute clauses, but not in the Modern Grammar, an expletive object *pro* is licensed.
2. There is a Tense head in Old Italian participial absolutes, absent in Modern Italian.

We have assumed that Tense is involved in the checking of Accusative. If checking of Accusative Case requires the presence of a T head, the licensing of object *pro*, that carries Accusative, must also depend on the T head. Notice, then, that our analysis can be simplified, as point (1), concerning object *pro*, does not need to be independently stated. There is always a T head in the finite clause, in Modern and Old Italian alike. In the participial clause, we assume a T head in Old but not in Modern Italian. Hence, the difference between Old and Modern Italian might follow without any assumption about the quality of AgrO; AgrO licenses *pro* in both grammars but the T head, necessary for the derivation to converge excludes *pro* from Modern Italian participial clauses and only from these. Point (1) has thus been derived from point (2).

The present account suffices to explain the data we are dealing with and my demonstration will stop here. It is obvious, though, that an exhaustive account for differences between Old and Modern Italian, concerning the syntax of participles in particular, must take other factors into consideration; addressing, above all, the question of Aspect, which has been disregarded here, and its correlation with Case theory. That problem goes beyond the purposes of this article.

Old Italian Texts cited:

Conv. *Il Convivio, Dante*. Presentazione, note e commenti di Piero Cudini, Garzanti 1980; III ed. 1990.

- Cron. *Cronica di Giovanni Villani*. Scelta, introduzione e note di Giovanni Aquilecchia, Einaudi, Torino 1979.
- Dec. *Decamerone*. A cura di Vittore Branca. Arnoldo Mondadori, Milano. 1 ed. Oscar classici, 1989.
- Espos. *Esposizioni sopra la Comedia di Dante, Boccaccio*. A cura di Giorgio Padoan. Arnoldo Mondadori, Milano, 1965.
- Fatti. *I fatti d'Enea, Guido da Pisa*. A cura di Francesco Fòffano, Sansoni, Firenze 1900; nuova presentazione di Franca Ageno, 1968.
- Nov.re. *Il Novelliere, Giovanni Sercambi*. A cura di Luciano Rossi, Salerno Editrice, Roma 1974; (I Novellieri Italiani, volume 9; tomo I.)
- Pec. *Il Pecorone, Ser Giovanni*. A cura di Enzo Esposito, Longo Editore, 1974, Ravenna.
- Trec. *Il Trecentonovelle, Sacchetti*. A cura di Antonio Lanza, Sansoni Editore, Firenze, 1984.
- Vizi. *Il Libro de' Vizi e delle Virtudi, Bono Giamboni*. A cura di Cesare Segre, Giulio Einaudi Editore, Torino 1968.

References

- Agno, F. (1964) «Il Verbo nell'italiano antico.» Riccardo Ricciardi Editore, Milano-Napoli.
- Authier, J.-M. (1992) «A Parametric Account of V-Governed Arbitrary Null Arguments.» *Natural Language and Linguistic Theory* 10, 345-374.
- Belletti, A. (1988) «The Case of Unaccusatives.» *Linguistic Inquiry* 19, 1-34.
- Belletti, A. (1990) «Generalized Verb Movement. Aspects of Verb Syntax.» Rosenberg & Sellier, Torino.
- Beninca, P. (ed.) (1989) «Dialect Variation and the Theory of Grammar.» Foris, Dordrecht.
- Bertinetto, P.M. (1986) «Tempo, Aspetto e Azione nel verbo italiano. Il sistema dell'indicativo.» Accademia della Crusca, Firenze.
- Bertuccelli Papi, M. (1991) «Participio passato.» in Renzi & Salvi (eds.).
- Bianchi, V. & M.C. Figueiredo Silva (1993) «On Some Properties of Agreement-Object in Italian and in Brazilian Portuguese.» ms Scuola Normale di Pisa and University of Genève.

- Bobaljik, J. & Jonas, D. (1993) «Subject Positions and the Role of TP.» talk presented at GLOW, Lund.
- Brandi, L. & P. Cordin (1989) «Two Italian Dialects and the Null Subject Parameter.» in Jacggli, O. & K. Safir (eds.), 111-142.
- Bramigan, P. (1992) «Subjects and Complementizers.» MIT Doctoral dissertation.
- Bures, A. (1993) «There is an Argument for an LF cycle here.» Chicago Linguistics Society 28 «The Role of the Cycle in Linguistic Theory.»
- Burzio, L. (1986) «Italian Syntax. A Government-Binding Approach.» Reidel, Dordrecht
- Cardinaletti, A. (1995) «Agreement and Control in Expletive Constructions.» ms. University of Venice.
- Cardinaletti, A. & M.T. Guasti (1992) «Epistemic Small Clauses and Null Subjects.» ESCOL Proceedings.
- Chomsky, N. (1986a) «Knowledge of Language.» Praeger, New York.
- Chomsky, N. (1986b) «Barriers.» Linguistic Inquiry Monograph 13, MIT Press, Cambridge, Mass.
- Chomsky, N. (1992) «A Minimalist Program for Linguistic Theory.» MIT Occasional Papers in Linguistics, 1.
- Chomsky, N. (1995) «Chapter four.» Draft, MIT.
- Cinque, G. (1990) «Ergative Adjectives and the Lexicalist Hypothesis.» *Natural Language and Linguistic Theory* 8, 1-40.
- Cinque, G. (1994) «Movimento del participio e struttura funzionale della frase.» talk presented at the XX Incontro di Grammatica Generativa, Padova.
- Cole, P. (1987) «Null Objects in Universal Grammar.» *Linguistic Inquiry* 18, 597-612.
- Déprez, V. (1989) «On the Typology of Syntactic Positions and the Nature of Chains.» MIT Doctoral dissertation.
- Egerland, V. (1994) «Sul verbo 'avere' ed il participio passato nell'italiano antico: un approccio generativo.» *Quaderni del Dipartimento di Linguistica, Università di Firenze* 5, 95-113.
- Egerland, V. (in preparation) «The Syntax of Past Participles. A Case Study on Non-Finite Constructions in Ancient and Modern Italian.» Doctoral thesis, University of Lund.

- Farrell, P. (1990) «Null Objects in Brazilian Portuguese.» *Natural Language and Linguistic Theory* 8, 325-346.
- Gunnarsson, K.-A. (1994) «Small Clauses and Absolute Constructions in Spanish» *Probus* 7, 125-171.
- Gärtner, H.-M. & M. Steinbach (1994) «Economy, Verb Second, and SVO-SOV Distinction.» *Working Papers in Scandinavian Syntax* 53, 1-59.
- Herczeg, G. (1972) «Saggi Linguistici e stilistici.» *Accademia Toscana di Scienze e Lettere «La Colombaria», XXIV*, Leo Olschki Editore, Firenze.
- Hoekstra, T. & I. Roberts (1993) «Middle Constructions in Dutch and English.» in Reuland, E. & W. Abraham (eds.) «Knowledge and Language. II: Lexical and Conceptual Structure.» Kluwer Academic Publishers.
- Holmberg, A. & C. Platzack (1995) «The Role of Inflection in Scandinavian Syntax.» Oxford University Press, New York, Oxford.
- Huang, J. (1984) «On the Distribution and Reference of Empty Pronouns.» *Linguistic Inquiry* 15, 531-575.
- Huang, J. (1989) «Pro-Drop in Chinese: a Generalized Control Theory.» in Jaeggli, O. & K. Safir (eds.)
- Jaeggli, O. & Safir, K. (eds.) (1989) «The Null Subject Parameter.» Kluwer, Dordrecht.
- Jonas, D. (1992) «Checking Theory and Nominative Case in Icelandic.» in *Harvard Working Papers in Linguistics* 1, 175-196.
- Junker, M.-O. & F. Martineau (1992) «The Structure of Infinitives.» *Probus* 4.
- Kayne, R.S. (1989) «Facets of Romance Past Participle Agreement.» in Benincà ed. (1989).
- Kayne, R.S. (1993) «Toward a Modular Theory of Auxiliary Selection.» *Studia Linguistica*, 47.
- Kayne, R.S. (1994) «The Antisymmetry of Syntax.» *Linguistic Inquiry Monograph* 25, MIT Press, Cambridge, Massachusetts.
- Kroch, A. (1994) «Morphosyntactic Variation.» to appear in K. Beals et al., eds. *Chicago Linguistics Society 30: Parasession on Variation and Linguistic Theory*.
- Lasnik, H. (1992) «Case and Expletives: Notes Toward a Parametric Account.» *Linguistic Inquiry* 23, 381-406.

- Madeira, A.M. (1994) «Inflected Infinitival Clauses in Portuguese.» talk presented at the XX Incontro di Grammatica Generativa, Padova.
- Mahajan, A. (1990) «The A/A'-Distinction and Movement Theory.» MIT Doctoral dissertation.
- Moro, A. (1993) «I predicati nominali e la struttura della frase.» Unipress, Padova.
- Platzack, C. (1994) «Null Subjects, Weak Agr and Syntactic Differences in Scandinavian.» Working Papers in Scandinavian Syntax, 53, 85-106.
- Pollock, J.-Y. (1989) «Verb Movement, UG and the Structure of IP.» *Linguistic Inquiry* 20, 365-424.
- Renzi, L. & G. Salvi (eds) (1991) «Grande grammatica italiana di consultazione. II.» Il Mulino, Bologna
- Rizzi, L. (1982) «Issues in Italian Syntax.» Foris, Dordrecht.
- Rizzi, L. (1986) «Null Objects in Italian and the Theory of pro.» *Linguistic Inquiry* 17, 501-557.
- Rizzi, L. (1991) «Residual Verb Second and the Wh-Criterion.» Technical Reports in Formal and Computational Linguistics, 2. Universite de Geneve.
- Roberts, I. (1987) «Implicit and Dethematized Subjects.» Foris, Dordrecht.
- Rohlf, G. (1969) «Grammatica storica della lingua italiana e dei suoi dialetti; Morfologia, Sintassi.» Einaudi, Torino.
- Santorini, B. (1989) «The Generalization of the Verb-Second Constraint in the History of Yiddish. Doctoral dissertation, University of Pennsylvania.
- Shlonsky, Ur (1990) «Pro in Hebrew Subject Inversion.» *Linguistic Inquiry* 21, 263-275.
- Sigurdsson, H. (1992) «Argument-Drop in Old Icelandic.» ms. Institute of Linguistics, University of Iceland.
- Sorrento, L. (1950) «Sintassi Romanza.» Istituto Editoriale Cisalpino, Varese-Milano.
- Sprouse, R.A. & B. Vance (1993) «An Explanation for the Loss of Null Subjects in Certain Romance and Germanic Languages.» talk presented at GLOW, Lund.
- Tekavčić, P (1972) «Grammatica storica dell'italiano II: Morfosintassi.» Il Mulino, Bologna

- Watanabe, A. (1993) «Agr-Based Case Theory and Its Interaction with the A-bar System.» MIT Doctoral dissertation.
- Zanuttini, R. (1991) «Syntactic Properties of Sentential Negation: A Comparative Study of Romance Languages.» Doctoral dissertation, University of Pennsylvania.
- Zwart, J.-W. (1993) «Dutch Syntax. A Minimalist Approach.» Doctoral dissertation, University of Groningen.
- Zwart, J.-W. (1994) «The Minimalist Program and Germanic Syntax. A Reply to Gartner and Steinbach.» Working Papers in Scandinavian Syntax 54, 1-41.